

**X-Rotor USER MANUAL**  
**Multi-Rotor**  
 Brushless Electronic Speed Controller  
 8A • 10A Mini • 10A • 20A • 40A

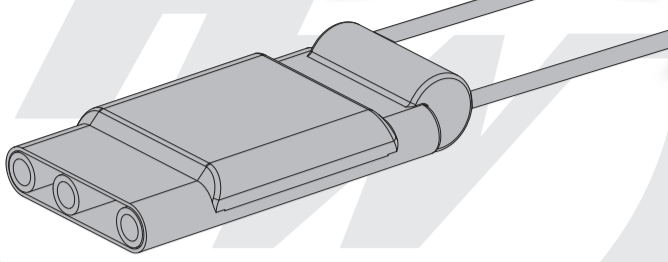

Thank you for purchasing this HOBBYWING product! Brushless power systems can be very dangerous. Any improper use may cause personal injury and damage to the product and related devices. We strongly recommend reading through this user manual before use. Because we have no control over the use, installation, or maintenance of this product, no liability may be assumed for any damage or losses resulting from the use of the product. We do not assume responsibility for any losses caused by unauthorized modifications to our product.

## 01 Features

- Special core program for multi-rotor controllers greatly improves throttle response.
- All settings except the timing are preset, making the usage really simple, highly intelligent and adaptive.
- The twisted-pair design of the throttle signal cable effectively reduces the crosstalk produced in signal transmission and makes flight more stable.
- Compatible with various flight-controllers and supports a signal frequency of up to 621Hz. (Notes: all throttle signals over 500Hz are non-standard signals.)

## 02 Specifications

Model	Con. Current	Peak Current (10s)	BEC	LiPo	Programmable Item	Weight	Size	Applications (For reference)
XRotor 8A	8A	12A	No	2S	Timing (High/Intermediate)	7g	44.2x12.2x9.2 mm	200/250 Class (Multi-rotor)
XRotor 10A-Mini-3S	10A	15A	No	2-3S	Timing (High/Intermediate)	7g	44.2x12.2x9.2 mm	250 Class (Multi-rotor)
XRotor 10A	10A	15A	No	2-3S	Timing (High/Intermediate)	6.5g	36.5x16.4x4.1 mm	250 Class (Multi-rotor)
XRotor 20A	20A	30A	No	3-4S	Timing (High/Intermediate)	14g	52.4x21.5x7 mm	330/450 Class (Multi-rotor)
XRotor 40A	40A	60A	No	2-6S	Timing (High/Intermediate)	26g	68x25x8.7 mm	550/650 Class (Multi-rotor)

## 03 User Guide

### Throttle Calibration & ESC Programming

- Users need to calibrate the throttle range when they start to use a new XRotor brushless ESC or another transmitter.
- Users can change the Timing setting when some abnormality occurs in the ESC driving the disc-type motor or need the motor to reach a higher RPM. (Note: Intermediate Timing is the default setting.)

### 1 Motor Wiring

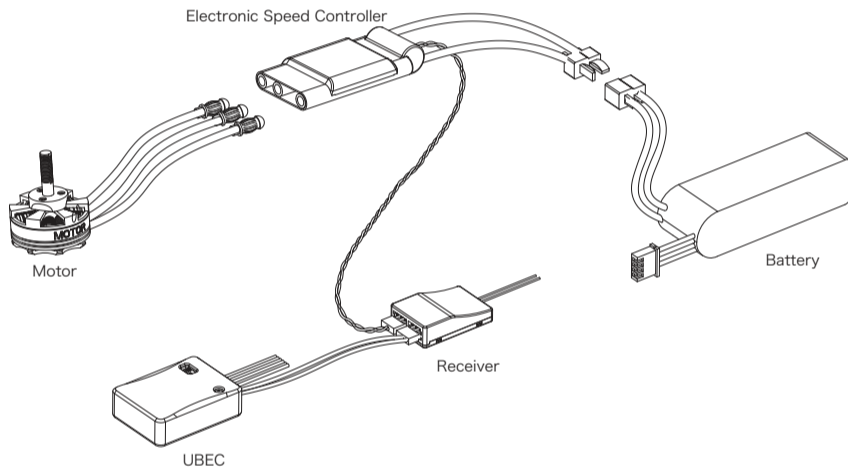

**IMPORTANT** This is an extremely powerful brushless motor system. We strongly recommend removing your propellers for your own safety and the safety of those around you before performing calibration and programming functions with this system.

### 2 Throttle Range Calibration



### 3 ESC Programming

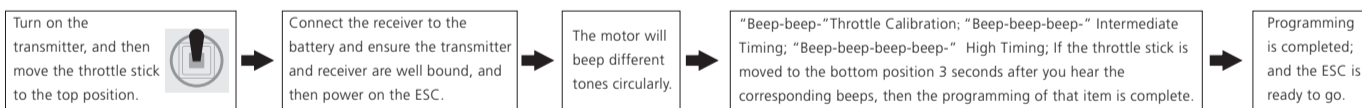

**IMPORTANT** Generally speaking, intermediate timing is applicable to most motors and it brings higher efficiency but less heat to the motors and speed controllers. High timing can increase the RPM of the motor, but it also increases the motor temperature. Please perform a test flight on the ground and ensure everything is functioning properly first, then fly your aircraft into the sky.

## 04 Normal Start-up Process and Protections

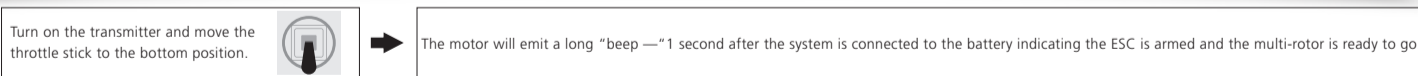

**Start-up Protection:** The ESC will shut down the motor if it fails to start the motor normally within 2 seconds by increasing the throttle value. In this case, you need to move the transmitter throttle stick back to the bottom position and restart the motor. (Possible causes of this problem: poor connection/ disconnection between the ESC and motor wires, propellers are blocked, etc.)

**Over-load Protection:** The ESC will cut off the power/output when the load suddenly increases to a very high value. Normal operation will not resume until the throttle stick is moved back to the neutral position. The ESC will automatically attempt to restart when the motor and the ESC are out of sync.

**Throttle Signal Loss Protection:** When the ESC detects loss of signal for over 0.25 second, it will cut off the output immediately to avoid an even greater loss which may be caused by the continuous high-speed rotation of propellers or rotor blades. The ESC will resume the corresponding output after normal signals are received.

## 05 Trouble shooting

Trouble	Warning Tone	Possible Cause	Solution
The ESC was unable to start the motor.	"Beep beep beep..." (The motor beeps rapidly)	The throttle stick is not at the bottom position.	Move the throttle stick to the bottom position or recalibrate the throttle range.
The ESC was unable to start the motor.	"Beep, beep, beep....." (Time interval is 1 second)	No output signal from the throttle channel on the receiver.	Check if the transmitter and receiver are well bound; Check if the throttle wire has been properly plugged into the throttle channel on the receiver.
The ESC was unable to start the motor.	"BB, BBB, BBBB" (These tones are played circularly)	The "Normal / Reverse" direction of the throttle channel on transmitter is incorrect.	Refer to the transmitter instructions and correctly set the "Normal/ Reverse" direction of the throttle channel.